

E15 A, B, D, E, G, J, K - 14V Replaces Valeo

E15 A, B, D, E, G, J, K - 14V Replaces Valeo

E15A

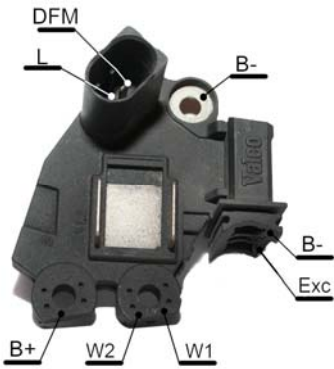

E15B



E1D

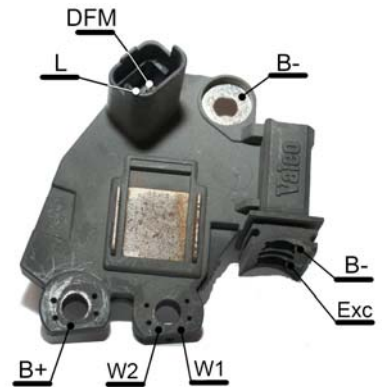

E15E

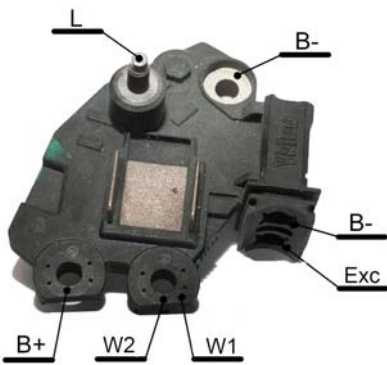

E15G

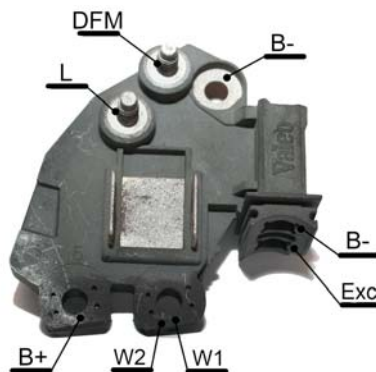

E1J

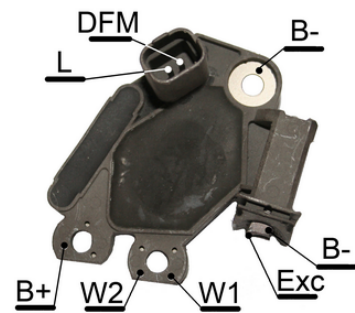

E15K

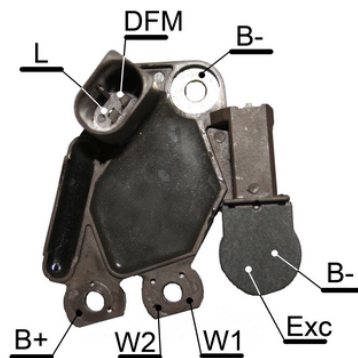

E15 A, B, D, E, G, J, K - 14V Replaces Valeo

Popis:

Jedná se o multifunkční autooscilační regulátory pro alternátory v automobilech. Obsahují kontrolní sekci, budící sekci a diagnostický okruh, který ovládá varovnou kontrolku.

Aplikační schéma:

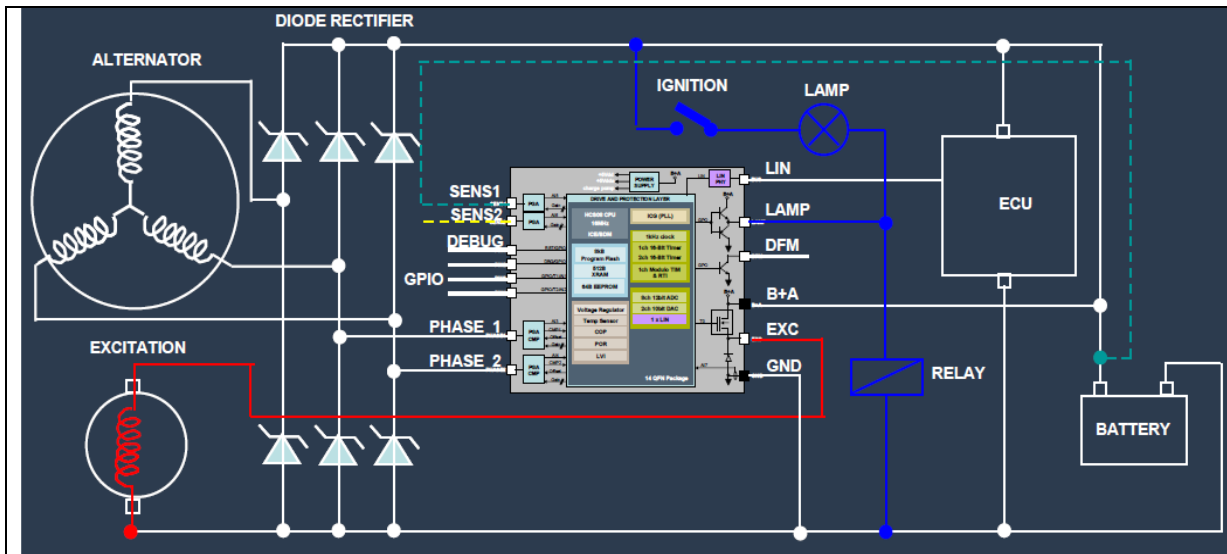

1.1 ELECTRICAL RATINGS

(-40°C to 140°C, unless otherwise stated)

Rating	Symbol	MIN value	Typical value	MAX value	Unit
B+A supply pin: DC Voltage	$V_{B+Acont}$			24	V
Transient voltage (Load Dump) Reverse ¹	$V_{B+Atrans}$ V_{B+Arev}	-2.5V		37	V
LAMP pin	$V_{MAX[LAMP]}$	-2		$V_{B+A}+1$	V
DF pin	$V_{MAX[DF]}$	-2		40	V
Phase pins	$V_{MAX[phase]}$	-40		40	V
EXC pin ¹	$V_{MAX[EXC]}$	-2.5		$V_{B+A}+1$	V

1. Dependant upon bond wire diameter and package

1.2 THERMAL RATINGS:

Rating	Symbol	MIN value	MAX value	Unit
Storage temperature	T_{stor}	-45	175	°C
Junction temperature	T_{op}	-40	160	°C
Parametric operating temperature	T_{pop}	-40	140	°C

2 Electrical characteristics

(-40°C to 140°C, unless otherwise stated)

Rating	Symbol	MIN value	typ value	MAX value	Unit
Operating normal V_{B+A}	V_{norm}	7		18	V
Quiescent current ¹	I_{SB}		400	500 ²	μ A
Operating current ³	I_{op}		12.0		mA
Range of regulation voltage (50%DC) ⁴	V_{reg}	14		15	V
ΔV_{reg} ⁵	ΔV_{reg}	-150		+150	mV
$\Delta V_{reg,load}$ ⁶	$\Delta V_{reg,L}$	-150		0	mV
$\Delta V_{reg,speed}$ ⁷	$\Delta V_{reg,S}$	-100		100	mV
LAMP power-up threshold voltage	V_{LAMP}	0.5		1.0	V
LAMP power-up threshold current	I_{LAMP}	0.1		0.5	mA
LAMP V_{on} @2mA ⁸	$V_{ON,L1}$	0.9		1.7	V
LAMP V_{on} @300mA ⁸	$V_{ON,L2}$	0.9		1.8	V
LAMP V_{on} @1A ⁸	$V_{ON,L3}$	0.9		2.5	V
TRIO V_{on} @1A ⁸	$V_{ON,T}$	0		0.5	V
EXC diode $V_{forward}$ @3A ⁸	$V_{F[diode]}$	0.6		1.4	V
EXC diode leakage ⁸	$V_{leak[diode]}$	-1 ⁹		10	μ A

Rating	Symbol	MIN value	typ value	MAX value	Unit
DF V_{on} (B+A=13V, R=300 Ω) ⁸	$V_{ON,DF1}$		1.0		V
DF V_{on} (B+A=13V, R=300 Ω) ¹⁰	$V_{ON,DFIT}$			2	V
DF V_{on} (B+A=13V, R=1700 Ω)	$V_{ON,DF2}$		0.3		V
FIELD $R_{DS_{ON}}$ ⁸	R_{DSON}^F			150	m Ω
FIELD TMOs leakage	$V_{leak[FIELD]}$	-10 ⁹		100	μ A
Over-current LAMP protection threshold	I_{LAMPCC}	0.8	1.4	2.2	A
Over-current TRIO protection threshold	I_{TRIOCC}	2		4	A
Over-current FIELD protection threshold	$I_{FIELDCC}$	15		20	A
Over-current DF protection threshold	I_{DFCC}		500		mA

1. Phase1 and Phase2 @0V
2. At 25°C.
3. 17%DC, no EXC or LAMP loads
4. See Table 1 for actual available values.
5. alternator speed 6000rpm, alternator output current=10A.
6. alternator speed 6000rpm, Field duty cycle from 5% to 90%.
7. alternator speed from 18000 rpm to 1500rpm, alternator output current=5A.
8. At 25°C.
9. The small negative limit is to allow for test equipment variation.
10. At 140°C.

3 Thermal characteristics (Junction).

Rating	Symbol	MIN value	typ value	MAX value	Unit
Over-temperature Field Shutdown threshold	T_{EXC}	160	180	190	°C
Over-temperature lamp Shutdown threshold	T_{LAMP}	160	175	190	°C
Over-temperature lamp Shutdown hysteresis	δT_{lamp}		10		°C
Regulation voltage primary TC ¹	TC_{reg}				mV/ °C

1. see Table 1: on page 9

4 Electrical over-stress characteristics

(@25°C unless otherwise stated)

Rating	Symbol	MIN value	typ value	MAX value	Unit
Load Dump ¹	V_{LD}			37	V
Reverse battery voltage (@ $\tau_{B+A}Rev$)	$V_{B+A}Rev$	-2.8 ²			V
Reverse battery duration (@ $V_{B+A}Rev$)	$\tau_{B+A}Rev$	5			s
Schaffner test ¹	$V_{Schaffner}$	-150		150	V

1. See Appendix A for test configuration

2. Duration is 10 seconds and the result is dependant on bond wire diameter and package

5 Dynamic Electrical Characteristics

(T_j = -40°C to 140°C)

Rating	Symbol	MIN value	For a typical alternator	MAX value	Unit
Regulation cycle frequency ¹	f _{reg}	60		80	Hz
Lack of phase Duty Cycle ²	DC _{noph}	15 27	17 29	19 31	%
Minimum Duty Cycle	DC _{min}	3		7	%
LOW phase voltage threshold ³	V _{LPH}	0.1		0.5	V
LOW phase speed threshold ⁴	Θ _{LPH}	120	140	160	Hz
LOW phase filter	f _{LPH}			50	kHz
Auto amorage on Phase1 ⁵	Θ _{AA1}			150	Hz
Auto amorage on Phase2 ⁵	Θ _{AA2}			150	Hz
HIGH phase voltage threshold	V _{HPH}	7.5	8.5	9.5	V
HIGH phase voltage hysteresis	ΔV _{HPH}		0.5		V
LRC disable frequency ⁶	Θ _{LRC}		2xΘ _{LPH}		Hz
Lamp switch ON delay ⁷	τ _{LON}	200		400	ms
Lamp switch OFF delay ⁷	τ _{LOFF}			18	ms
Duty Cycle Error [DF:EXC] ⁸	τ _{DF:EXC}	-2		2	%

1. See Table 3 for frequency ranges, depending on number of poles in alternator and required cut-in speed.

2. Typical 17%DC for CP type or 29%DC for LRC type regulators.

3. For 2-phase operation threshold is the difference between PHASE1 and PHASE2.

4. See Table 3 for frequency ranges, depending on number of poles in alternator and required cut-in speed.

5. Typical speed requirement for the alternator to obtain V_{LPH} threshold

6. Option LRC has only PHASE2.

7. Dependent on regulation frequency.

8. Percentage difference between switching edges of DF and EXC outputs.

6 Dynamic Electrical Characteristics (Cont.)

(T_j = -40°C to 140°C)

Rating	Symbol	MIN value	typ value	MAX value	Unit
Over-voltage detection threshold	V _{OV}	1.04x V _{reg}		1.10x V _{reg}	V
Over-voltage detection qualification	V _{EXCDET}	0.2		1.0	V
Low-voltage detection threshold	V _{LV}		0.80x V _{reg}		V
Low-voltage detection qualification ¹	Θ _{LV}	240	280	320	Hz
UnderVoltage	V _{VCCLB}		8.5		V
Power-On-Reset threshold	V _{POR}		5		V
Proportional Voltage Band on V _{reg}	V _{PVB}	40		150	mV
Delta CP Duty Cycle	ΔCP	3.0		3.2	%
Number of CP steps ²	η _{CP}	31	32	32	n

1. See Table 3 for frequency ranges, depending on number of poles in alternator and required cut-in speed.
2. N.B. 31 is the maximum that can exist, however testing may detect 32.

7 Environmental characteristics

(@25°C unless otherwise stated)

Rating	Standard	Value
Susceptibility	ISO11452-2 ISO11452-4	@100V/m @200mA
Emissions	VDE0879 C15PR/D/WG2	@200mA
ESD (IC)	MIL883 (HBM)	+/-2KV
ESD (LAMP) ¹	IEC801	+/-4KV
ESD (DF) ¹	IEC801	+/-3kV ²
Transients	ISO7637-1	Appendix A

1. Regulator mounted on the alternator
2. Voltages in excess of this can require external protection components.

8 ADJUSTMENTS/SETTINGS

Suffix	Regulation voltage (V)	Precision (mV)
C, E, H, I, J, L, T	14.55	+/-100
K	14.30	+/-100

Table 1: Model type and regulation voltage at 20°C.

Suffix	δ temp mV/K	Precision mV/K
C, E, H, L, T	-10	+/- 2
	-7	+/- 2
	-5	+/-2
I, J	-3.5	+/- 1
K	-0	+/- 1

Table 2: Model Type and Temperature Coefficient.

Suffix	Cut-in speed rpm	N ^o of pole-pairs	Cut-in Frequency Hz	Θ_{LV} Hz	F _{osc} kHz	F _{reg} Hz
E, H, K, T	1400	6	140.0	280.0	143.4	68.4
	1400	8	186.7	373.3	191.1	91.1
J	1440	6	144.0	288.0	147.5	70.5
I	1440	8	192.0	384.0	196.6	93.8
	1600	6	160.0	320.0	163.8	78.1
	1600	8	213.3	426.7	218.5	104.2
C, L	1800	6	180.0	360.0	184.3	87.9
	1800	8	240.0	480.0	245.8	117.2

Table 3: Model Type and Cut-in RPM/PHASE speed

Prog. table T, T, T, T

E15 A, B, D, E, G, J, K - 14V Replaces Valeo

Suffix	η_{CP}	PAD CP1	PAD CP2
	0s	0	0
	2.5s	1	0
	5s	0	1
E, H	10s	1	1

Table 4: CP Fuse Settings

0: FUSE IN PLACE
1: FUSE BLOWN

0s :No CP functionality
2.5s :2.5s at a PHASE frequency of 180Hz
5s :5s at a PHASE frequency of 180Hz
10s :10s at a PHASE frequency of 180Hz

Suffix	η_{LRC}	PAD CP1	PAD CP2
	0s	0	0
K, L, T	2.5s	1	0
I, J	5s	0	1
C	10s	1	1

Table 5: LRC Fuse Settings

0: FUSE IN PLACE
1: FUSE BLOWN

0s :No LRC functionality
2.5s :Time from 0% to 100%DC = 2.5s
5s :Time from 0% to 100%DC = 5s
10s :Time from 0% to 100%DC = 10s