

## Multifunkční regulátor E5-14V– 859 405 090 0653

Replaces Valeo- No China

### Přehled vlastností:

- Plně jednoduchý design
- Teplotní ochrana
- Ochrana před zkratem

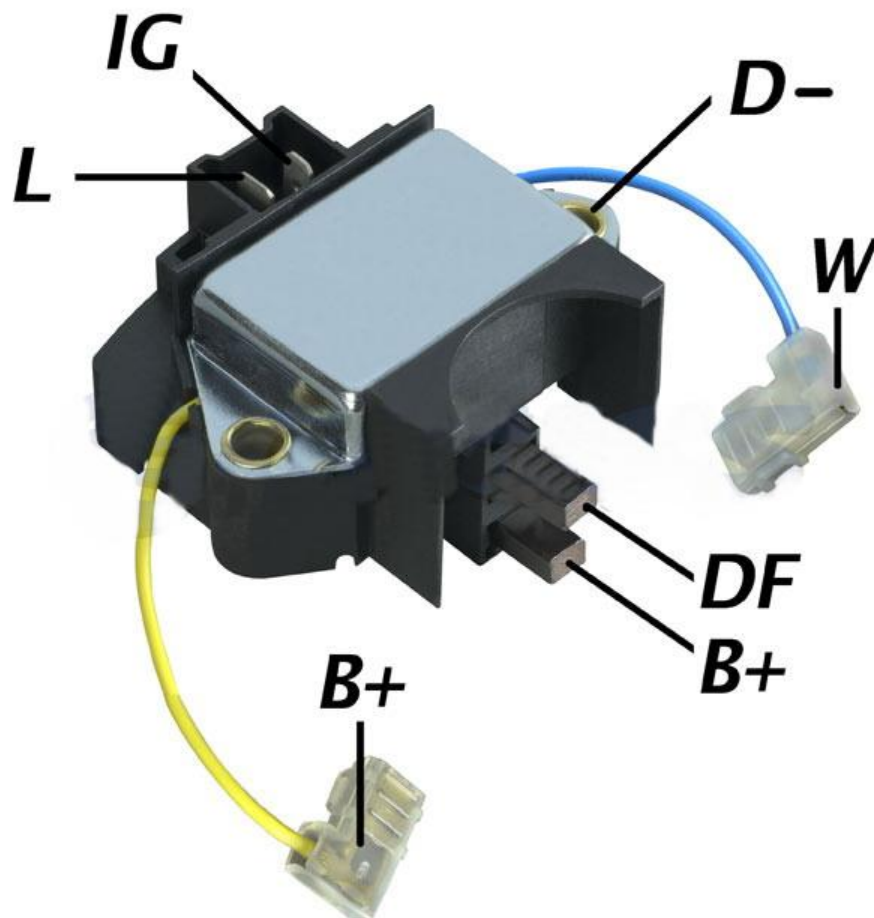
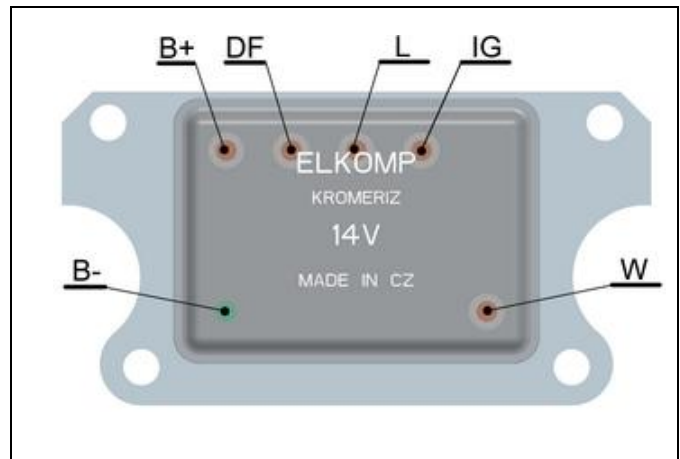

**Application:** Renault, Saab, Volvo, Maseraty, MB1920

## Popis:

Jedná se o multifunkční autooscilační regulátory pro alternátory v automobilech. Obsahují kontrolní sekci, budící sekci a diagnostický okruh, který ovládá varovnou kontrolku.

## Aplikační schéma:

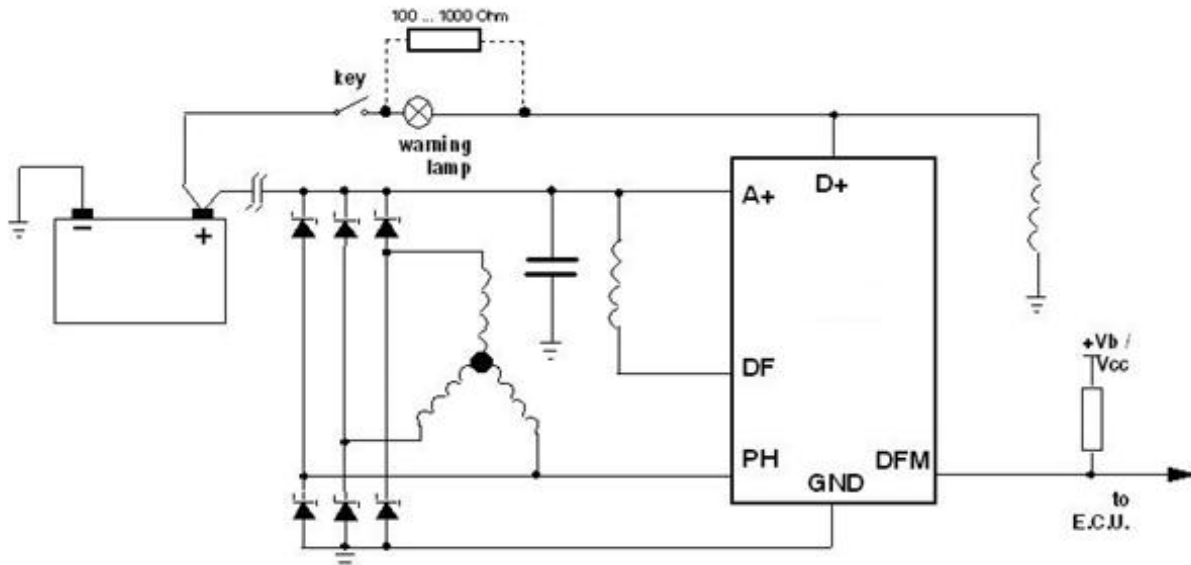

## Elektrické specifikace

### Maximální hodnoty

Symbol	Parametr	Hodnota	Jednotka
VS	DC Supply Voltage (2 min. @ 25°)	24	V
	Transient Supply Voltage (load dump); t < 0.5s @ 25°C	40	V
	Transient Supply Voltage (low energy spikes pulse ISO7637/1)	60	V
IO	Output Current Capability	internally limited	A
Ptot	Power Dissipation(@ Tcase = 150°C, I <sub>field</sub> = 5A)	Tbd	
	Reverse Voltage all pins @ 25°C, T = 15s	-2.5	V
	DC Pin Current (bonding limitation) on DF, A+, GND pins	11	A
	EDS Voltage (Human body model)	±4	KV

### Teplotní údaje

Symbol	Parametr	Hodnota	Jednotka
T <sub>case</sub>	Case temperature	-40 to 160	°C
T <sub>stg</sub>	Storage temperature	-40 to 170	°C
T <sub>sh</sub>	Thermal shutdown	185 ±15	°C
R <sub>th j-case</sub>	Thermal Resistance Junction-case Max.	1.5	°C/W

### Elektrické specifikace

( $-40\text{ °C} \leq T_J \leq 125\text{ °C}$ , pokud není uvedeno jinak)

Symbol	Parameter	Test Condition	Min.	Typ.	Max.	Unit
$V_{bat}$	Operating Supply Voltage		8.5		18	V
$I_{bsink}$	Supply Battery Current				50	mA
$I_{bstby}$	Stand-by Current	$V_{bat} = 12V, T = 25\text{ °C}$			300	$\mu A$
		$V_{bat} = 12V, T = 40\text{ °C}$			500	
$V_{reg}$	Regulated Voltage & Therm. Drift (standard version)	$I_{alt} = 0.5 \cdot I_{nom};$ $rpm = 0.5 \cdot RPM_{MAX}; T = 20\text{ °C}$	14.3 -4	14.45 -3	14.6 -2	V mV/°C
$V_{reg}^{(1)}$	Regulated Voltage & Therm. Drift (optional version)	$I_{alt} = 0.2 \cdot I_{nom};$ $rpm = 0.5 \cdot RPM_{MAX}; T = 20\text{ °C}$	14.1 -11.5	14.5 -10	14.9 -8.5	V mV/°C
$f_{sw}$	Switching Frequency	in FSDF	30		400	Hz
$V_{rpm}$	Delta $V_{rpm}$	$1800 < rpm < 12000;$ $I_{alt} = 0.3 \cdot I_{nom}$			200	mV
$V_{load}$	Delta $V_{load}$	$0.1 \cdot I_{nom} < I_{alt} < 0.9 \cdot I_{nom};$ $rpm = 0.5 \cdot rpm_{max}$			200	mV
$V_{reg}$	Reg. Voltage without Battery	$I_{alt} = 3A$ resistive			16	V
$V_{OV}$	D+ Drivers Disable Therseshold	Voltage on pin A+ to have D+ = OFF	18		22	V
$T_{j-sd}$	Thermal Shut-down	DF = OFF STATE D+ = OFF STATE	170		200	°C
$T_{j-sd-hys}$	Thermal Shut-down Hysteresis	DF, D+ = from off state (due to thermal shutdown) to on	2		10	°C
$R_{on}$	Low Side Driver $R_{dson}$	$T = 150\text{ °C}; I = 5A$			230	m $\Omega$
$R_{on}$	Low Side Driver $R_{dson}$	$T = 25\text{ °C}; I = 5A$			130	m $\Omega$
$V_F$	Freewheeling Diode DF	$I_F = 5A$			2	V
$I_{fsc}$	Short Circuit Threshold DF	DF = 12V; $T = -40$ to $25\text{ °C}$	8.5		18	A
$I_{fsc}$	Short Circuit Threshold DF	DF = 12V; $T = 25$ to $125\text{ °C}$	7		18	A
$V_{s1}$	Output Short to GROUND Threshold DF		2.1		3.9	V
FSDF	Pre-excitation F.S.D.F	$f = 348\text{Hz} \pm 15\%$	10.62	12.5	14.38	%

Multifunkční regulátor E5-14V– 859 405 090 0653

Symbol	Parameter	Test Condition	Min.	Typ.	Max.	Unit
$t_{ST}$	Soft Start Delay Time	activated at first running-on only		0		s
$t_{SL}$	Soft Attack Time	from 0 to 100% field duty cycle	2.5	2.88	3.39	s
BI	Soft Attack Blind Zone	% of maximum D.C. immediate variation of soft attack	0		10	%
$t_{rise}$	Output Voltage Rise Time	$I_{field} = 3A$ resistive	5		50	$\mu s$
$t_{fall}$	Output Voltage Fall Time		5		50	$\mu s$
$I_{fk}$	Output Field Driver Leakage Current	DF = 24V			1	mA
$V_{HS}$	High Side Driver Saturation Voltage	$I_{source} = 1A$			1.2	V
$V_{LS}$	Low Side Driver Saturation Voltage	$I_{sink} = 0.25A$			1.5	V
VLSB	Selfbias without supply lamp driver voltage				4	V
IHSC	High Side Current Limitation	A+ = 17.5V; D+ = GND	1.2		3	A
ILSC	Low Side Current Limitation	A+ = D+ = 17.5V	0.45		1.5	A
$V_{thD+}$	Enable Regulator Voltage D+		0.8	1	1.15	V
$I_{thD+}$	Enable Regulator Pull-down Current		0.4		3.5	mA
DISAB	Soft Attack Inhibition Frequency		265	313	360	Hz
EN <sub>1</sub>	Soft start delay time enable frequency		88	104	120	Hz
EN <sub>1_hy</sub>	Soft start delay time enable frequency hysteresis		E <sub>N1-8</sub>	E <sub>N1-10</sub>	E <sub>N1-12</sub>	Hz
VPHL1	Enable Control Voltage PH high threshold	Square wave 1KHz	0.67	0.795	0.92	V
VPHL2	Enable Control Voltage PH low threshold		VPHL1 -0.48	VPHL1 -0.57	VPHL1 -0.66	V
$t_{PH}$	PH Filtering Time		15		120	$\mu s$
VPHH1	Diag. Phase Loss High Voltage		9	10.25	11.5	V
VPHH2	Diag. Phase Loss Low Voltage		4	5	6	V
$t_{PHD}$	Diagnostic PH Filtering Time		50		200	$\mu s$
$I_{PH}$	Phase Pull-down Current		1		8	mA
$t_D$	Diagnostic Alarm Delay		0.48	0.575	0.65	s
$f_{DFM}$	DFM Open Drain Switching Frequency	in FSDF	30		400	Hz
$V_{ol}$	Output Low Voltage DFM	$I_{sink} = 25mA$			1.5	V

Symbol	Parameter	Test Condition	Min.	Typ.	Max.	Unit
$I_{dfml}$	Short Circuit Protection DFM	VDF_MON = 12V	25		200	mA
$I_{lk}$	Output Leakage Current DFM	VDF_MON = 24V			0.1	mA
$t_{TM}$	DFM Output Voltage rise time	R = 2.7k $\Omega$ ; C = 1nF; V <sub>alim</sub> = 13.5V	0.05		50	$\mu$ s
T_TD	DFM Output Voltage fall time	R = 2.7k $\Omega$ ; C = 1nF; V <sub>alim</sub> = 13.5V	0.05		50	$\mu$ s

(1) Available through a metal option of the actual device.

## Teplotní kompenzace

Teplota (°C)	V <sub>reg</sub> (V)		
	Min.	Typ.	Max.
-40	14.43	14.645	14.86
25	14.30	14.45	14.60
125	13.90	14.15	14.40

