

Multifunkční regulátor E7D-14V (LIN) – 859 405 090 0448

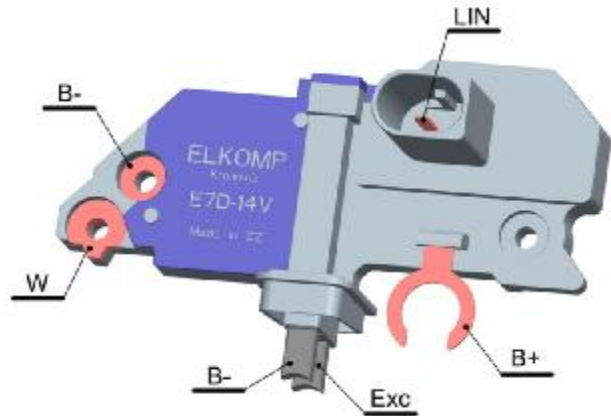

Popis:

Regulátor LIN je integrovaný obvod určený k regulování výstupního napětí na alternátoru v automobilu. Tento regulátor poskytuje vedle kontroly napětí také kontrolu LRC a má rozhraní pro průmyslový standard LIN tak, aby byla ECU vedle dalších parametrů umožněna i kontrola regulovaného napětí a hodnoty LRC a číst tak hodnoty o stavu regulátoru a alternátoru. Tento okruh byl speciálně vytvořen pro použití v nepříznivém prostředí motoru automobilu.

Schéma zapojení

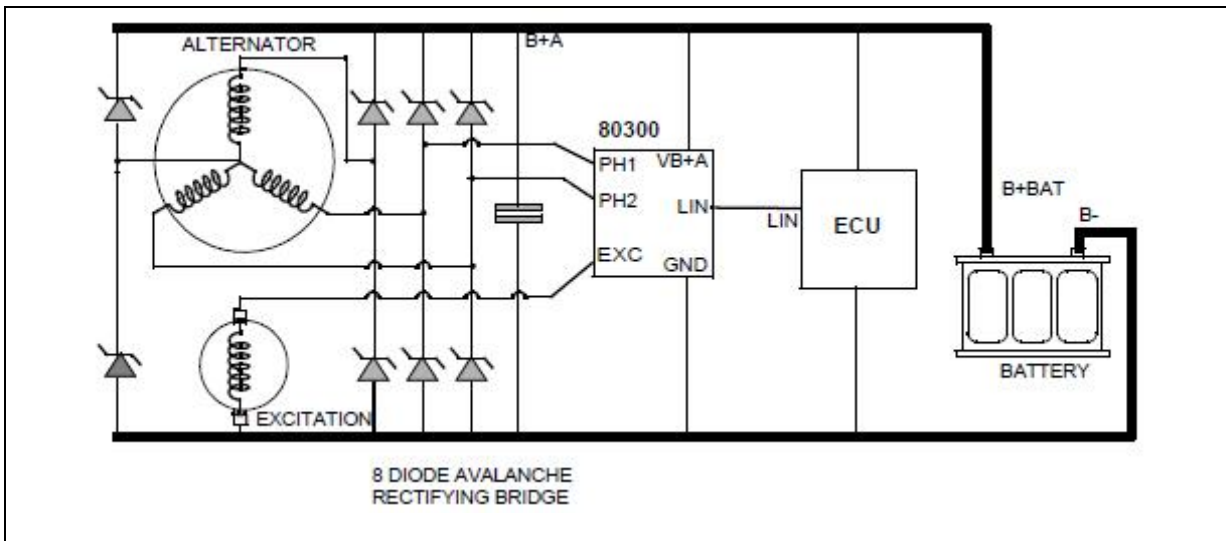

Elektrické specifikace

Table 1. Maximum Ratings

All voltages are with respect to ground unless otherwise noted. Exceeding these ratings may cause a malfunction or permanent damage to the device. $T_A = 25^\circ\text{C}$, unless otherwise stated.

Ratings	Symbol	Value	Unit
ELECTRICAL RATINGS			
B+A supply pin DC Voltage	V_{B+cont}	27	V
Load Dump Transient Voltage (ISO7637-2)	$V_{B+trans}$	40	V
Maximum reverse B+A Voltage ⁽¹⁾ (5 seconds)	V_{-B+A}	-2.4	V
Maximum Excitation Current at $T_J = 180^\circ\text{C}$	I_{EXC}	5	A
Maximum Excitation Current at $T_J = 25^\circ\text{C}$	I_{EXC}	8	A
Recirculation Diode Peak Current		8	A
Recirculation Diode Reverse Voltage		40	V
PHASE Input voltage range	V_{PHASE}	+/-40	V
BUS Pin Input Range		-2 to +40	V
ESD Voltage ⁽²⁾ Human Body Model - All Pins (MIL std 883C) Charge Device Model - Corner Pins - All Pins Accessible Pins (EN61.000-4-2) when mounted on the alternator (LIN & B+A) by contact discharge	V_{ESD1} V_{ESD2} V_{ESD3} V_{ESD4}	+/-8000 (4A) +/-750 +/-500 +/-8000 (30A)	V
Standard Transient Pulses ISO7637-1 & -3	Level	+/-150	V
THERMAL RATINGS			
Storage Temperature	T_{stor}	-45	$^\circ\text{C}$
Operating Junction Temperature ⁽³⁾	T_J	-40	$^\circ\text{C}$
Thermal Shutdown Temperature	$T_{J.TSD}$	175	$^\circ\text{C}$
Thermal Shutdown Hysteresis	$T_{TSD.HYST}$	10	$^\circ\text{C}$

Notes

1. Not tested. Depends on package and bonding.
2. Testing is performed in accordance with the Human Body Model ($C_{zap}=100\text{pF}$, $R_{zap}=1500\text{ohms}$), Charge Device Model, Robotic ($C_{zap}=4.0\text{pF}$), or the EN61000-4-2 specification ($C_{zap}=150\text{pF}$, $R_{zap}=330\text{ohms}$).
3. Guaranteed by Design.

STATIC ELECTRICAL CHARACTERISTICS

Table 2. Static Electrical Characteristics (T_J from -40°C to 140°C , unless otherwise noted, operation is guaranteed by design up to $T_{J,TSB}$).

Rating	Symbol	Min	Typ	Max	Unit
Operating Voltage, V_{B+A}	V_{B+A}	8		27	V
Bus Operating Voltage	$V_{B+A,BUS}$	8		18	V
Quiescent Current at 12.5V (Phases at 0V) (including phase currents at 25°C)	$I_{SB2,B+A,0}$			110	μA
Quiescent Current at 12.5V (Phases at 12.5V) (including phase currents at 25°C)	$I_{SB2,B+A,1}$			250	μA
Operating Current no EXC load at 25°C and $V_{bat}=14\text{V}$	I_{op}		14		mA
Range of Regulation Voltage (50% DC)	V_{REG}	10.60		16.0	V
V_{REG} Setting Accuracy Voltage at 50% for $V_{REG}=13.8\text{V}$ and $T_J = 25^{\circ}\text{C}$	ΔV_{REG1}	-100		+100	mV
V_{REG} Setting Accuracy Voltage at 50% for $V_{REG}=10.7\text{V}$ and $V_{REG}=16\text{V}$ and $T_J = 25^{\circ}\text{C}$	ΔV_{REG2}	-150		+150	mV
Load Dump Detection Threshold Voltage	V_{LD}		21		V
ΔV_{REG} with load Voltage ⁽⁴⁾	$\Delta V_{REG,L}$	-150		0	mV
ΔV_{REG} with speed Voltage ⁽⁵⁾	$\Delta V_{REG,S}$	-100		100	mV
$R_{DS,ON}$ FIELD TMOS at $I_{EXC} = 5\text{A}$ and $T_J = 140^{\circ}\text{C}$ ⁽⁶⁾	$R_{DS,ON,EXC}$			100	m Ω
Over-voltage detection ⁽⁷⁾	$V_{EXC,SEN}$		0.6		V
Recirculation Diode Voltage at 5A (Excitation Current)	V_F		1.2	1.5	V
Phase Input High Threshold Voltage (PHASE OK)	$V_{P,H}$		8		V
Phase Input High Hysteresis Voltage (PHASE OK)	$V_{PH,HYST}$		1		V
Overvoltage (Fault) Threshold Voltage	V_{OV}		16.5		V
EXC short-circuit protection threshold ⁽⁸⁾	$I_{EXC,SC}$		10		A
LIN peak short-circuit current	$I_{LIN,SC}$			150	mA

Notes

4. Changing load from 5% to 90% of alternator capability.
5. At low load (5%) and varying alternator speed from 18000RPM to 2000RPM. By design, not tested.
6. The thermal capability of the packaging is critical to the full use of the output drive.
7. If there is a high voltage and the EXC pin is above this voltage a fault is detected.
8. Pulsed at low duty-cycle.

FUNCTIONAL DEVICE OPERATION

LOGIC COMMANDS AND REGISTERS

OTP FEATURES

Special Features Enabled by OTP:

- The dual alternator address is 110101.
- The LIN 0x3C global shutdown command can be used to immediately put the regulator into the standby state.
- Low Voltage detection (at $V < 75\% V_{REG}$ and above the LRC cut-off speed).

Fault Indications (from left to right in the Data Fields 1 & 2) for First Data:

- Electrical Fault (F_EL).
- Mechanical fault (F_MEC).

- High Temperature (F_HT).
- LIN Bus Timeout (3 or 8 seconds by OTP, then load defaults from OTP).
- Communication Error (same timeout and action as for LIN Bus Timeout).

Fault Indications (from left to right in the Data Field 2) for Second Data:

- N ... Sync Break Error.
- O ... Identifier Parity Error.
- P ... Checksum Error.
- Q ... "Slave not Responding" Error.

Table 4. OTP Programmable Options.

Function	OTP	OTP Bits	Comments.
Default Regulation Voltage	YES	4	13.5V to 15.0V
Phase start regulating RPM ⁽¹²⁾	YES	3	800 - 2500 RPM
Phase stop regulating RPM ⁽¹²⁾	YES	2	500 - 1000 RPM
LRC Disable RPM Default ⁽¹²⁾ , 4 RPM choices (2400, 3000, 4000 & never)	YES	2	ECU has 16 settings, 2400 -8000 RPM and never
LRC Rate Default, 4 choices (0, 3.0, 6.4 & 12.3 seconds)	YES	2	ECU has 16 settings, 0 seconds (no LRC) to 13.2 seconds.
Alternator Pole-Pairs	YES	2	6, 7, 8 & 9
Slave Address	YES	1	Two address options, A or B
Phase Sensitivity (Start-up)	YES	2	Hysteresis (650-2400mV)
Self-Start (Auto-Amorcage)	YES	1	Yes or No.
Bus Inactivity or Data Corruption Timeout	YES	1	3 or 8 seconds
Default LIN Readout Temp or EXC current	YES	1	Select Temperature or Current
Thermal Fault Threshold	YES	2	135°C, 145°C, 150°C, 160°C
Current Measurement Averaging	YES	2	1, 4, 8, 16 samples
Low Voltage Threshold	YES	1	75% or none
Input Divider Adjust	YES	3	Tolerance compensation
Date Code/Traceability	YES	12	TBD, date code or wafer
Alternator Supplier and Class	YES	3+5	Alternator Information.

Table 4. OTP Programmable Options.

Function	OTP	OTP Bits	Comments.
Security "Lock Bits"	YES	2	One each for probe and EOL.
Crest Regulation	YES	1	Enabled or disabled (unprogrammed)
Parity Bit	YES	1	Data Protection
Special LIN Features	YES	1	Enabled or Disabled ⁽¹³⁾

Notes

12. These are adjustable independently, the IC internally compensates for the pole-pairs if the correct OTP setting is made. Frequency measurements are made over multiple cycles for greater accuracy.
13. See page 9 for details.

PROTECTION AND DIAGNOSIS FEATURES

FAULT DETECTION

General Notes

A "mechanical fault" is detected by the lack of both PHASE signals or a very low frequency PHASE signal.

Electrical faults are:

- A high voltage accompanied by an EXC voltage above the $V_{EXC.SEN}$ threshold.
- A low voltage at a speed above the LRC disable speed (enabled by OTP).
- The failure of active PHASE input to attain the high level (~8V).

- No transition on high phase of non active phase detected between two low phase detections (low phase RPM above stop regulation threshold).
- OTP parity check error.
- Short circuit excitation load.

A Thermal Fault is reported when the die temperature exceeds the programmed threshold.

All fault reporting passes through a 400ms digital filter to avoid false indication problems, and transition from one fault type to another should be "clean".

LIN BUS INFORMATION

Warning: All data bus information is preliminary and subject to change to meet updated car company requirements.

Notes: Two alternators are possible, identified as IDA and IDB.

The LIN Bus Timeout is 3 seconds (8 seconds option), upon timeout the default conditions are set and the transmission error bit is set.

The LIN transceiver will accept bus speeds between 2.4k and 19.2k baud.

The regulator shall only give pre-excitation when it receives a LIN command targeted for it (so to IDA or IDB), the shutdown command is the code that would otherwise set 10.6V ("000000").

LIN (MID) addresses are listed in [LSB:MSB] format, while data fields are listed in [MSB:LSB] format.

Table 5. LIN Command Information.

Function	LIN	Active Bits
V_{REG} Digital	W	6
LRC Rate	W	4
LRC Disable Frequency	W	4
Excitation Current Limitation (0A to 7.75A)	W	5
Status & Diagnostic	R	5

Multifunkční regulátor E7D-14V (LIN) – 859 405 090 0448

Table 5. LIN Command Information.

Function	LIN	Active Bits
EXC Duty-Cycle	R	5
Excitation Current	R	6 ⁽¹⁴⁾
Die Temperature	R	6 ⁽¹⁵⁾
Manufacturing Information	R	8
Regulated Voltage	R	6

Notes

14. Whilst this information is given as 6 bits it is only accurate:

a) from 0°C to 25°C:

- from 0A to 3.875A: +/- 375mA

- from 3.875A to 7.75A: +/- 10%

b) outside the previous temperature range:

- from 0 to 3.875A: +/-625mA

- from 3.875A to 7.75A: +/-15%

Currents higher than 7.75A, which may be possible at low temperature, are reported as 7.75A. Excitation Current and Die Temperature functions are exclusive.

15. Whilst this gives a resolution of 3.5 degrees the accuracy is +/-10 degrees. Excitation Current and Die Temperature functions are exclusive.

Table 6. LIN Data Format⁽¹⁶⁾

Rx Frame IDA 100101 IDB 010101 IDA & IDB 110101 ⁽¹⁷⁾			
DATA 1	DATA 2	DATA 3	DATA 4
xx Target Voltage (6)	LRC: Off (4), Rate (4)	xxx Limit Current (5)	xxxxxxx
2 Byte Data 1 Tx Frame IDA 100010 IDB 110010		2 Byte Data 2 Tx Frame IDA 010010 IDB 001010	
DATA 1	DATA 2	DATA 1	DATA 2
DFM (5), DIAG (3,)	DIAG (2), Current (6)	Manufacturer (3), Class (5)	NO PQxxxx
Master Task	Alternator (Slave) Task	Alternator (Slave) Task	

Notes

16. All address data is for the form IDA[0:5].

17. This allows the ECU in a dual alternator system to adjust both at the same time.